

Machine Screws Head Dimensions

Round Phillips Binding

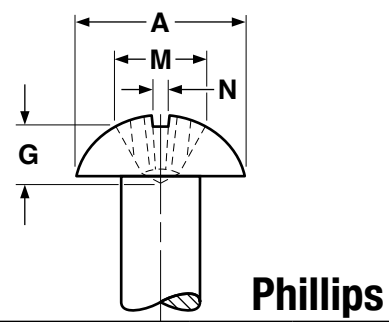
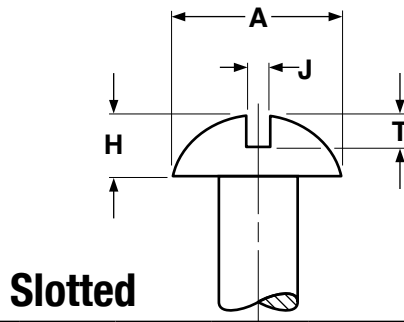

ROUND HEADS FOR MACHINE SCREWS

ASME B18.6.3
2002

Nominal Size	A		H		J		T		M		G	N	Phillips Driver Size
	Head Diameter		Height of Head		Width of Slot		Depth of Slot		Dimensions of Recess				
									Diameter		Depth	Width	
	Max	Min	Max	Min	Max	Min	Max	Min	Max	Min	Max	Min	
2	.162	.146	.069	.059	.031	.023	.048	.037	.100	.087	.053	.017	1
3	.187	.169	.078	.067	.035	.027	.053	.040	.109	.096	.062	.018	1
4	.211	.193	.086	.075	.039	.031	.058	.044	.118	.105	.072	.019	1
5	.236	.217	.095	.083	.043	.035	.063	.047	.154	.141	.074	.027	2
6	.260	.240	.103	.091	.048	.039	.068	.051	.162	.149	.084	.027	2
8	.309	.287	.120	.107	.054	.045	.077	.058	.178	.165	.101	.030	2
10	.359	.334	.137	.123	.060	.050	.087	.065	.195	.182	.119	.031	2
12	.408	.382	.153	.139	.067	.056	.096	.073	.249	.236	.125	.032	3
1/4	.472	.443	.175	.160	.075	.064	.109	.082	.268	.255	.147	.034	3
5/16	.590	.557	.216	.198	.084	.072	.132	.099	.308	.295	.187	.040	3
3/8	.708	.670	.256	.237	.094	.081	.155	.117	.387	.374	.228	.064	4
1/2	.813	.766	.355	.332	.106	.091	.211	.159	.416	.403	.256	.068	4

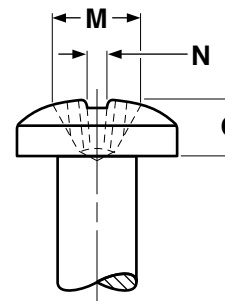
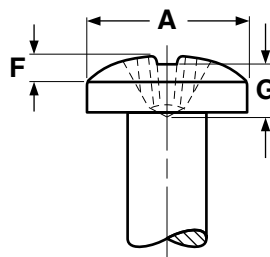

PHILLIPS BINDING HEADS FOR MACHINE SCREWS

ASME B18.6.3-2002

Nominal Size	A		O		F		M		G		N	Phillips Driver Size
	Head Diameter		Total Head Height		Head Oval Height		Recess Diameter		Recess Depth		Recess Width	
	Max	Min	Max	Min	Max	Min	Max	Min	Max	Min	Min	
2	.181	.171	.050	.043	.018	.013	.100	.087	.058	.041	.017	1
4	.235	.223	.068	.061	.025	.018	.118	.105	.077	.059	.017	1
6	.290	.275	.087	.078	.032	.024	.160	.147	.088	.064	.026	2
8	.344	.326	.105	.095	.039	.029	.186	.173	.114	.090	.028	2
10	.399	.378	.123	.112	.045	.034	.205	.192	.134	.109	.029	2
1/4	.525	.498	.165	.152	.061	.046	.281	.268	.164	.140	.046	3