

**Combo Round
Combo Truss**

Head Dimensions

Machine Screws

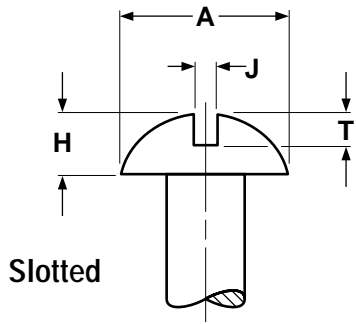

Slotted

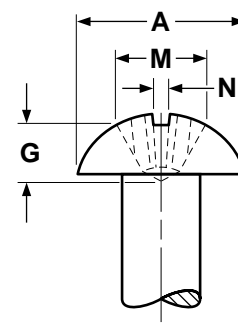
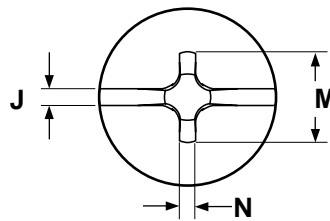

Phillips

COMBINATION DRIVE ROUND HEADS FOR MACHINE SCREWS

Nominal Screw Size	A		H		J		T		M		G		N	Recess Penetration Gaging Depth		Driver Size
	Head Dimensions				Slot Dimensions				Recess Dimensions							
	Head Diameter		Head Height		Width		Depth		Diameter		Depth		Recess Width	Recess Penetration Gaging Depth		
	Max	Min	Max	Min	Max	Min	Max	Min	Max	Min	Max	Min	Min	Max	Min	
4	.211	.193	.086	.075	.039	.031	.058	.044	.118	.105	.072	.053	.019	.065	.046	1
6	.260	.240	.103	.091	.048	.039	.068	.051	.162	.149	.084	.056	.027	.073	.045	2
8	.309	.287	.120	.107	.054	.045	.077	.058	.178	.165	.101	.075	.030	.090	.064	2
10	.359	.334	.137	.123	.060	.050	.087	.065	.195	.182	.119	.093	.031	.108	.082	2
12	.408	.382	.153	.139	.067	.056	.096	.073	.249	.236	.125	.099	.032	.108	.082	3
1/4	.472	.443	.175	.160	.075	.064	.109	.082	.268	.255	.147	.121	.034	.130	.104	3
5/16	.590	.557	.216	.198	.084	.072	.132	.099	.308	.295	.187	.161	.040	.170	.144	3
3/8	.708	.670	.256	.237	.094	.081	.155	.117	.387	.374	.228	.202	.064	.208	.182	4

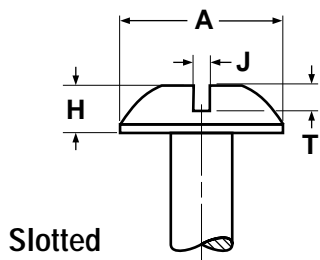

Slotted

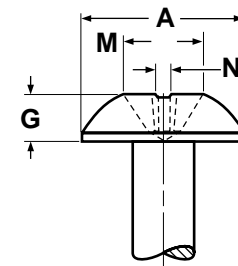
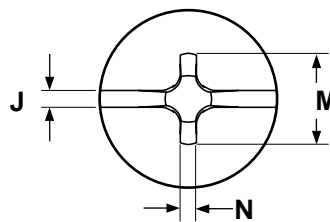

Phillips

COMBINATION DRIVE TRUSS HEADS FOR MACHINE SCREWS

Nominal Size	A		H		J		T		M		G		N	Recess Penetration Gaging Depth		Phillips Driver Size
	Head Diameter		Height of Head		Width of Slot		Depth of Slot		Dimensions of Recess							
									Diameter		Depth		Width	Recess Penetration Gaging Depth		
	Max	Min	Max	Min	Max	Min	Max	Min	Max	Min	Max	Min	Min	Max	Min	
4	.257	.241	.069	.059	.039	.031	.040	.030	.112	.099	.069	.051	.018	.062	.044	1
6	.321	.303	.086	.074	.048	.039	.050	.037	.158	.145	.084	.059	.027	.073	.048	2
8	.384	.364	.102	.088	.054	.045	.058	.045	.173	.160	.099	.074	.029	.088	.063	2
10	.448	.425	.118	.103	.060	.050	.068	.053	.188	.175	.115	.090	.030	.104	.079	2
12	.511	.487	.134	.118	.067	.056	.077	.061	.248	.235	.128	.103	.032	.111	.086	3
1/4	.573	.546	.150	.133	.075	.064	.087	.070	.263	.250	.143	.118	.033	.126	.101	3