

# Flat Head

# METRIC

# Machine Screws

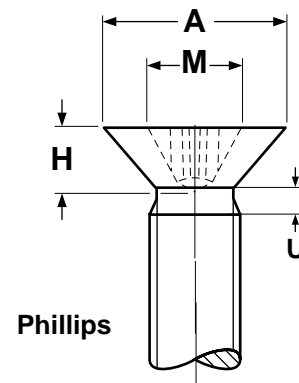
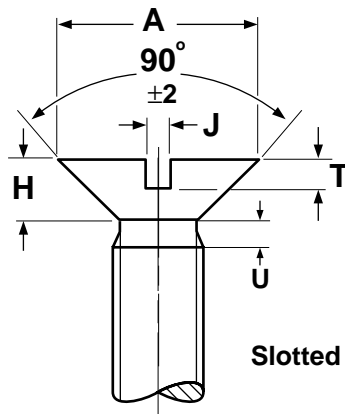

## METRIC - PHILLIPS FLAT HEADS FOR MACHINE SCREWS

ISO 7046-1

Nominal Size	Thread Pitch	A		H	M	G		U	Phillips Driver Size
		Head Diameter		Head Height	Recess Diameter	Recess Penetration		Thread Runout	
		Max	Min	Max	Ref	Max	Min	Max	
M1.6	0.35	3.0	2.7	1	1.6	0.9	0.6	0.7	0
M2	0.4	3.8	3.5	1.2	1.9	1.2	0.9	0.8	0
M2.5	0.45	4.7	4.4	1.5	2.9	1.8	1.4	0.9	1
M3	0.5	5.5	5.2	1.65	3.2	2.1	1.7	1	1
M4	0.7	8.40	8.04	2.7	4.6	2.6	2.1	1.4	2
M5	0.8	9.30	8.94	2.7	5.2	3.2	2.7	1.6	2
M6	1	11.30	10.87	3.3	6.8	3.5	3.0	2	3
M8	1.25	15.80	15.37	4.65	8.9	4.6	4.0	2.5	4
M10	1.5	18.30	17.78	5	10	5.7	5.1	3	4

## METRIC - SLOTTED FLAT HEADS FOR MACHINE SCREWS

ISO 2009

Nominal Size	Thread Pitch	A		H	J		T		U
		Head Diameter		Head Height	Width of Slot		Depth of Slot		Thread Runout
		Max	Min	Max	Max	Min	Max	Min	Max
M1.6	0.35	3.0	2.7	1	0.60	0.46	0.50	0.32	0.7
M2	0.4	3.8	3.5	1.2	0.70	0.56	0.6	0.4	0.8
M2.5	0.45	4.7	4.4	1.5	0.80	0.66	0.75	0.50	0.9
M3	0.5	5.5	5.2	1.65	1.00	0.86	0.85	0.60	1
M4	0.7	8.40	8.04	2.7	1.51	1.26	1.3	1.0	1.4
M5	0.8	9.30	8.94	2.7	1.51	1.26	1.4	1.1	1.6
M6	1	11.30	10.87	3.3	1.91	1.66	1.6	1.2	2
M8	1.25	15.80	15.37	4.65	2.31	2.06	2.3	1.8	2.5
M10	1.5	18.30	17.78	5	2.81	2.56	2.6	2.0	3