

Retaining Rings

External Type

Carbon Spring Steel
& Stainless Steel

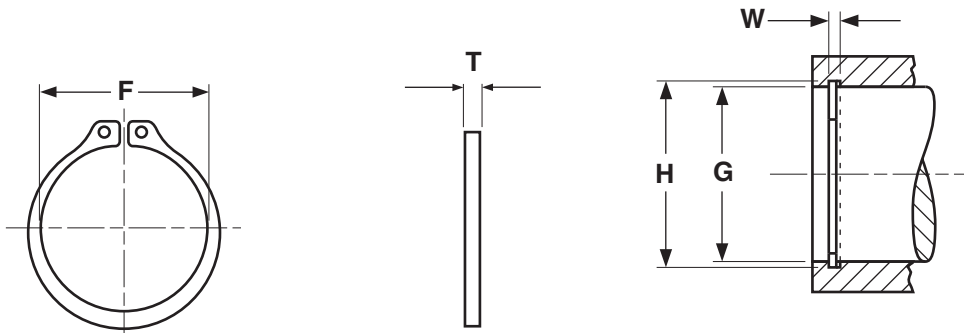

EXTERNAL TYPE RETAINING RINGS

Carbon Spring Steel		Stainless Steel		H	G	W	F	T
Kanebridge Part Number	Waldes Part Number	Kanebridge Part Number	Waldes Part Number	Shaft	Groove Diameter	Groove Width	Free Diameter	Thickness
25REXBP	5100-25STPP	25REXSS	5100-25H	0.250	0.230	0.029	0.225	0.025
28REXBP	5100-28STPP	28REXSS	5100-28H	0.281	0.261	0.029	0.256	0.025
31REXBP	5100-31STPP	31REXSS	5100-31H	0.312	0.290	0.029	0.281	0.025
34REXBP	5100-34STPP	-	5100-34H	0.344	0.321	0.029	0.309	0.025
37REXBP	5100-37STPP	37REXSS	5100-37H	0.375	0.352	0.029	0.338	0.025
40REXBP	5100-40STPP	-	5100-40H	0.406	0.382	0.029	0.366	0.025
43REXBP	5100-43STPP	43REXSS	5100-43H	0.438	0.412	0.029	0.395	0.025
50REXBP	5100-50STPP	50REXSS	5100-50H	0.500	0.468	0.039	0.461	0.035
56REXBP	5100-56STPP	56REXSS	5100-56H	0.562	0.530	0.039	0.521	0.035
59REXBP	5100-59STPP	59REXSS	5100-59H	0.594	0.559	0.039	0.550	0.035
62REXBP	5100-62STPP	62REXSS	5100-62H	0.625	0.588	0.039	0.579	0.035
68REXBP	5100-68STPP	68REXSS	5100-68H	0.688	0.646	0.046	0.635	0.042
75REXBP	5100-75STPP	75REXSS	5100-75H	0.750	0.704	0.046	0.693	0.042
81REXBP	5100-81STPP	81REXSS	5100-81H	0.812	0.762	0.046	0.751	0.042
87REXBP	5100-87STPP	87REXSS	5100-87H	0.875	0.821	0.046	0.810	0.042
93REXBP	5100-93STPP	93REXSS	5100-93H	0.938	0.882	0.046	0.867	0.042
100REXBP	5100-100STPP	100REXSS	5100-100H	1.000	0.940	0.046	0.925	0.042
106REXBP	5100-106STPP	106REXSS	5100-106H	1.062	0.998	0.056	0.982	0.050
112REXBP	5100-112STPP	112REXSS	5100-112H	1.125	1.059	0.056	1.041	0.050
118REXBP	5100-118STPP	118REXSS	5100-118H	1.188	1.118	0.056	1.098	0.050
125REXBP	5100-125STPP	125REXSS	5100-125H	1.250	1.176	0.056	1.156	0.050
131REXBP	5100-131STPP	131REXSS	5100-131H	1.312	1.232	0.056	1.214	0.050
137REXBP	5100-137STPP	137REXSS	5100-137H	1.375	1.291	0.056	1.272	0.050
143REXBP	5100-143STPP	-	5100-143H	1.438	1.350	0.056	1.333	0.050
150REXBP	5100-150STPP	150REXSS	5100-150H	1.500	1.406	0.056	1.387	0.050
156REXBP	5100-156STPP	-	5100-156H	1.562	1.468	0.068	1.446	0.062
162REXBP	5100-162STPP	162REXSS	5100-162H	1.625	1.529	0.068	1.503	0.062
168REXBP	5100-168STPP	-	5100-168H	1.688	1.589	0.068	1.560	0.062
175REXBP	5100-175STPP	175REXSS	5100-175H	1.750	1.650	0.068	1.618	0.062

EXTERNAL TYPE RETAINING RINGS (CONTINUED)								
Carbon Spring Steel		Stainless Steel		H	G	W	F	T
Kanebridge Part Number	Waldes Part Number	Kanebridge Part Number	Waldes Part Number	Shaft	Groove Diameter	Groove Width	Free Diameter	Thickness
181REXBP	5100-181STPP	-	5100-181H	1.812	1.708	0.068	1.675	0.062
187REXBP	5100-187STPP	-	5100-187H	1.875	1.769	0.068	1.735	0.062
200REXBP	5100-200STPP	200REXSS	5100-200H	2.000	1.886	0.068	1.850	0.062
206REXBP	5100-206STPP	-	5100-206H	2.062	1.946	0.086	1.906	0.078
212REXBP	5100-212STPP	-	5100-212H	2.125	2.003	0.086	1.964	0.078
225REXBP	5100-225STPP	-	5100-225H	2.250	2.120	0.086	2.081	0.078
231REXBP	5100-231STPP	-	5100-231H	2.312	2.178	0.086	2.139	0.078
237REXBP	5100-237STPP	-	5100-237H	2.375	2.239	0.086	2.197	0.078
243REXBP	5100-243STPP	-	5100-243H	2.438	2.299	0.086	2.255	0.078
250REXBP	5100-250STPP	-	5100-250H	2.500	2.360	0.086	2.313	0.078
262REXBP	5100-262STPP	-	5100-262H	2.625	2.481	0.086	2.428	0.078
268REXBP	5100-268STPP	-	5100-268H	2.688	2.541	0.086	2.485	0.078
275REXBP	5100-275STPP	-	5100-275H	2.750	2.602	0.103	2.543	0.093
287REXBP	5100-287STPP	-	5100-287H	2.875	2.721	0.103	2.659	0.093
300REXBP	5100-300STPP	-	5100-300H	3.000	2.838	0.103	2.775	0.093

Description	A ring-shaped stamping with one opening on the circumference. The two ends at the opening are called lugs and flare out slightly allowing for easier installation onto shafts.	
Applications/ Advantages	The external retaining ring is for axial assembly into machined grooves on shafts. Tapered section design assures uniform circular deformation, allowing for complete contact and tightness in groove. Steel rings can be safely used within a temperature range of -100°F to 500°F. Stainless steel rings are corrosion resistant & can be used in higher heat applications from -100°F to 900°F.	
Material	<i>Steel</i>	<i>Stainless</i>
	Carbon spring steel SAE 1060 - 1090	Precipitation Hardened Alloy 15% Chromium, 7% Nickel, 2% Molybdenum
Heat Treatment	Retaining rings are heat treated using the austempering method. Rings are uniformly heated to temperatures over 1500° F. They are then isothermally quenched in a molten salt bath at 600° F for 35 minutes. This results in parts with a bainite structure characterized by good mechanical properties.	
Hardness	<i>Sizes 25 & 46:</i> Rockwell 30N 69.5 - 73 <i>Sizes 50 - 81:</i> Rockwell 30N 66 - 71 <i>Sizes 87 - 102:</i> Rockwell C 47 - 53 <i>Sizes 106 - 343:</i> Rockwell C 47 - 52	<i>Sizes 25 - 31:</i> Rockwell 30N 63 - 69.5 <i>Sizes 87 & over:</i> Rockwell C 44 - 51
	-	225,000 psi. minimum
Tensile Strength	-	
Finish	See Appendix-A for information about the coating of retaining rings.	