

Dome Head
Blind Rivet

Copper Rivet/ Copper-plated Mandrel

Rivets

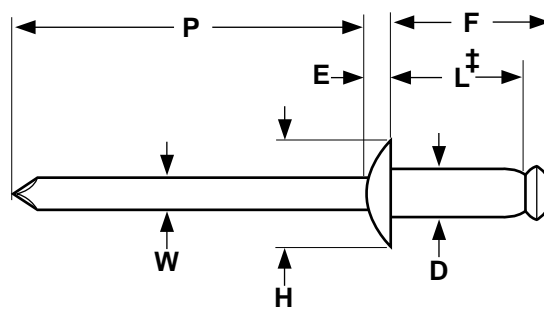

COPPER BODY/COPPER-PLATED STEEL MANDREL, DOME HEAD BREAK-STEM BLIND RIVETS										SAE J-1200
Nominal Rivet Diameter	D		H		E	W	P	F	Mandrel Break Load	
	Rivet Shank Diameter		Head Diameter		Head Height	Mandrel Diameter	Mandrel Protrusion	Blind Side Protrusion	Max	Min
	Max	Min	Max	Min	Max	Nom	Min	Max	Max	Min
1/8	0.128	0.122	0.262	0.238	0.040	0.076	1.00	L + 0.120	600	400

Description	A copper blind fastener with a self-contained steel mandrel which is otherwise designed identically to an aluminum rivet with a steel mandrel. The head of the rivet body is slightly rounded and twice as wide as the body diameter.
Applications/ Advantages	Dome head is the only head style in which the copper rivet is offered. Copper rivets are not subject to tensile or shear strength testing, but meet the same mandrel break-load standards as aluminum rivets with steel mandrels. Copper is the most malleable of the various rivet metals. It has a higher electrical conductivity than any of the other rivet metals which make it useful in many electrical applications. They should be used when fastening materials with mechanical and physical properties similar to copper.
Material	<i>Rivet:</i> Copper Alloy No. 110. <i>Mandrel:</i> Carbon steel 1006 or equivalent, copper plated.
Shear Strength	Copper rivets are not subject to shear testing (SAE J1200).
Tensile Strength	Copper rivets are not subject to tensile testing (SAE J1200).
Mandrel Break Load	While the rivet is being set, the axially applied load necessary to break the mandrel shall be within 600 lbs. max, and 400 lbs. min.

PART NUMBER COMPARISON - DOME HEAD COPPER RIVET/COPPER-PLATED STEEL MANDREL							
Kanebridge	Huck/ Automatic	Pop®	Marson/ Creative	Star	Celus®	Cherry	Gesipa®
KDS42	CBS42	CD42BS	CB4-2	-	C/S 42D	USP-42	-
KDS43	CBS43	-	-	-	-	USP-43	-

®Celus is a registered trademark of Celus Fasteners Manufacturing Inc..

®Gesipa is a registered trademark of Gesipa Fasteners USA Inc..

®Pop is a registered trademark of Pop Fastening Systems, Emhart Fastening Technologies, a Black & Decker Company. Kanebridge's rivets are not manufactured by or connected with the producers of Gesipa® or Pop® rivets.

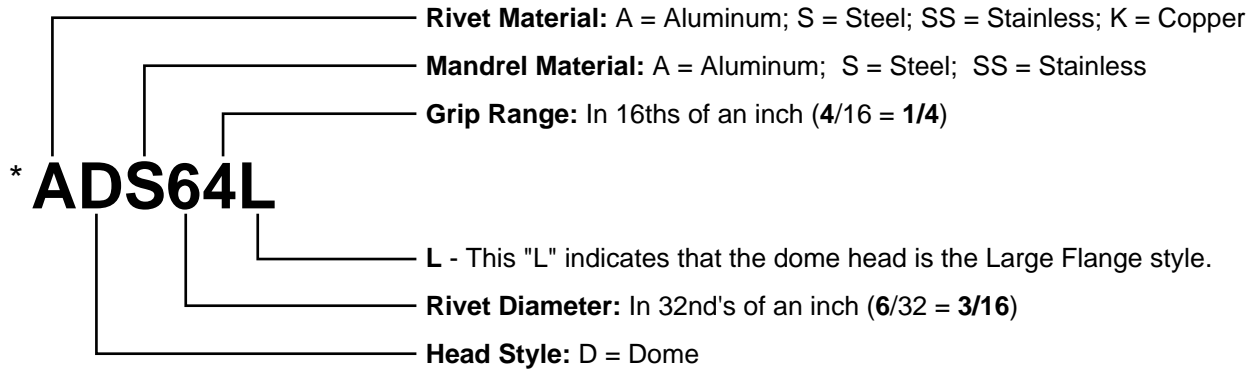

*Kanebridge Part Number

Notes on Rivet Selection

Strength- The tensile and shear strengths required for an application must be determined and a rivet selected that meets those requirements.

Materials- Choose a rivet that is made of a metal with similar mechanical and physical properties as the materials being joined. This is especially critical in assemblies where higher temperatures and/or corrosive elements are present. Metal compatibility helps reduce the risks of galvanic corrosion and material fatigue.

Grip Range- Measure the total thickness of the materials being fastened. This is known as the "rivet grip". The grip ranges of the most commonly available rivets are listed in the table below. Sufficient rivet length is necessary for proper formation of the secondary head on the blind side of the assembly. Multi-grip rivets have wider grip ranges than standard break-stem blind rivets.

APPLICATION DATA FOR STANDARD BREAK-STEM BLIND RIVETS											SAE J-1200
Rivet Number	Grip Range	Barrel Length	Recommended Hole Size		Drill Size	Rivet Number	Grip Range	Barrel Length	Recommended Hole Size		Drill Size
			Max	Min					Max	Min	
31	.020-.062	.187	0.100	0.097	#41	62	.020-.125	.325	0.196	0.192	#11
32	.020-.125	.250									
33	.087-.187	.312									
34	.126-.250	.375									
41	.020-.062	.212	0.133	0.129	#30	68	.376-.500	.700			
42	.063-.125	.275									
43	.126-.187	.337									
44	.188-.250	.400									
45	.251-.312	.462									
46	.313-.375	.525									
48	.376-.500	.650									
52	.020-.125	.300	0.164	0.160	#20	610	.510-.625	.825	0.261	0.257	F
53	.125-.187	.362									
54	.188-.250	.425									
56	.251-.375	.550									
58	.376-.500	.675									
510	.501-.625	.800									
512	.626-.750	.925									
516	.876-1.000	1.175									
									84	.126-.250	.500
						86	.251-.375	.625			
						88	.376-.500	.750			
						810	.501-.625	.875			
						812	.626-.750	.990			
						816	.751-1.000	1.240			