

Slotted & Unslotted Hex Washer  
With & Without Serrations

SELF-PIERCING

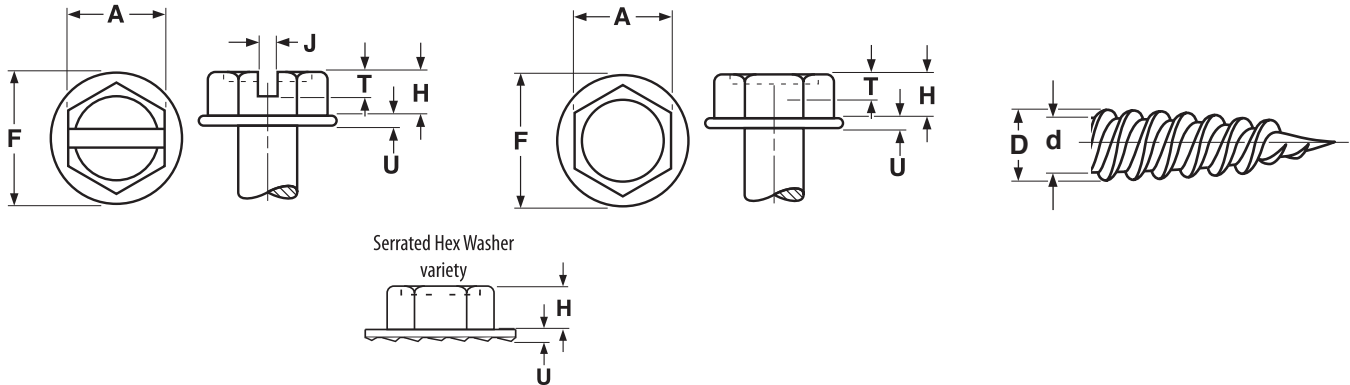

HEX WASHER HEAD SELF-PIERCING SCREWS

| Size                       | A                  |      | H           |      | F               |      | U                |       | J          |      | T          |      | D              |      | d              |      |
|----------------------------|--------------------|------|-------------|------|-----------------|------|------------------|-------|------------|------|------------|------|----------------|------|----------------|------|
|                            | Width Across Flats |      | Head Height |      | Washer Diameter |      | Washer Thickness |       | Slot Width |      | Slot Depth |      | Major Diameter |      | Minor Diameter |      |
|                            | Max                | Min  | Max         | Min  | Max             | Min  | Max              | Min   | Max        | Min  | Max        | Min  | Max            | Min  | Max            | Min  |
| 6-18                       | .250               | .244 | .093        | .080 | .328            | .302 | .025             | .015  | .048       | .039 | .053       | .033 | .141           | .136 | .102           | .096 |
| 7-16                       | .250               | .244 | .093        | .080 | .328            | .302 | .029             | .017  | .048       | .039 | .062       | .040 | .158           | .152 | .114           | .108 |
| 8-15                       | .250               | .244 | .110        | .096 | .348            | .322 | .031             | .019  | .054       | .045 | .074       | .052 | .168           | .162 | .123           | .116 |
| 10-12                      | .250               | .244 | .110        | .096 | .414            | .384 | .031             | .019  | .054       | .045 | .074       | .052 | .194           | .188 | .133           | .126 |
|                            | .312               | .305 | .120        | .105 | .414            | .384 | .031             | .019  | .060       | .050 | .074       | .052 | .194           | .188 | .133           | .126 |
| 10-16                      | .250               | .244 | .110        | .096 | .414            | .384 | .031             | .019  | .054       | .045 | .074       | .052 | .194           | .188 | .133           | .126 |
|                            | .312               | .305 | .120        | .105 | .414            | .384 | .031             | .019  | .060       | .050 | .074       | .052 | .194           | .188 | .133           | .126 |
| 12-11                      | .312               | .305 | .150        | .133 | .432            | .398 | .039             | .022  | .067       | .056 | .093       | .077 | .221           | .215 | .162           | .155 |
| 14-10                      | .375               | .366 | .190        | .171 | .520            | .479 | .050             | .029  | .075       | .064 | .111       | .082 | .254           | .247 | .200           | .178 |
| <b>Tolerance on Length</b> |                    |      |             |      |                 |      |                  | ±0.05 |            |      |            |      |                |      |                |      |

NOTE: There is no single standard for self-piercing screw dimensions. These values are offered as a guide; deviations from these specifications may occur.

|  |  |   |
|--|--|---|
| <b>Description</b>                     | A hex washer head thread forming tapping screw with a single lead thread rolled to the tip of an extra sharp point, and a second thread spaced 180° apart. Head can be slotted or unslotted. The bearing surface of the washer is sometimes ordered with serrations. |   |
| <b>Applications/ Advantages</b>        | May be used in thin metal (less than .050 thick). Eliminates need for pre-drilled or pre-punched holes. Undercut area beneath the head allows greater length of thread engagement. Twin lead threads help to reduce driving torque.                                  | The 18-8 variety offers greater corrosion resistance than the zinc-plated steel screw, but since it is not hardenable, its tip cannot puncture as wide a range of metals. The 410 stainless screw is more corrosion-resistant than a steel screw but less than the 18-8. Since the 410 screw is hardenable, it can pierce a wider variety of metals than the 18-8 type, but can become brittle in low temperatures. |
| <b>Material</b>                        | AISI 1018 - 1022 or equivalent steel   | 18-8 or 410 stainless   |
| <b>Heat Treatment</b>                  | Screws shall be quenched in liquid and then tempered by reheating to 650°F minimum.  | 410 stainless screws shall be hardened and tempered by heating to 1800-1900°F sufficient for austenization, held for at least 1/2 hour and rapid air or oil-quenched, then reheating to 500-600°F for at least 1 hour and air cooled to provide the specified hardness.   |
| <b>Surface Hardness</b>                | Rockwell C45 minimum   | 410 SS: Rockwell C55 minimum  |
| <b>Case Depth</b>                      | <i>No. 6 diameter:</i> .002 - .007<br><i>No. 7 thru 12 diameter:</i> .004 - .009<br><i>1/4" diameter:</i> .005 - .011  | -   |
| <b>Core Hardness (after tempering)</b> | Rockwell C28 - 38  | 410 SS: Rockwell C38 - 42 (after tempering)   |
| <b>Plating</b>                         | See Appendix-A for plating information.  | Stainless self-piercing screws are usually supplied plain.  |